

Quick Installation Guide

Step 1: Installation

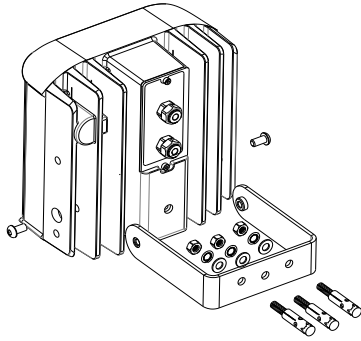

1. Make sure the bracket is firmly installed to the illuminator.

2. Install the illuminator and the camera at the desired position.

3. Remove the cord grip cover plate from the back of the illuminator so that access to the controls behind the cover plate is possible.

4. Connect the illuminator to a 24V AC or 24 – 36V DC power supply by first feeding the power cable through the lower cord grip in the cover plate, and then attaching the 2-pin power connector to the power cable. When attaching the power connector please take extra care not to leave any exposed wire, as this may cause a short. If necessary, trim back the wires.

5. Setup the video security camera so that you can see a good image from the video security camera on a computer or TV monitor.

6. Put the camera in "night mode" or IR cut filter removed mode.

7. Power on the illuminator, make sure it is at full brightness (rotate Brightness Adjustment control fully clockwise), and rotate the Ambient Light Threshold Adjustment control fully clockwise (this will force the illuminator to be ON regardless of the ambient light level). It is common to see a faint red glow from the illuminator. Do not stare into the illuminator for long periods of time (see safety notes at the end of the manual).

8. While viewing the output of the video security camera adjust the Angle of Illumination Adjustment control until the light beam from the illuminator is just slightly larger than the parts of the scene you are going to focus the camera to. The light beam should be only 5-10% larger than the object or area you are trying to view with the camera.

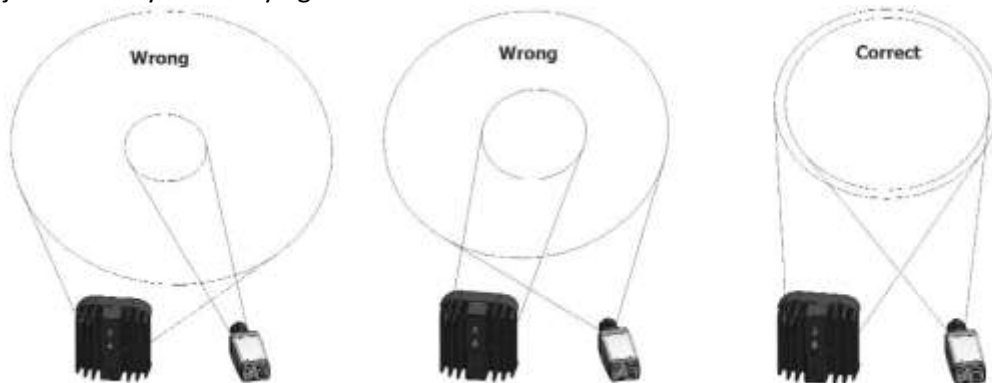

9. Once the light beam is properly set, zoom the camera to the scene as well.

10. Adjust the Brightness Adjustment control lower if there is too much illumination.

11. Adjust the Ambient Light Threshold Adjustment control to the desired ambient light level for turn-on. The status LED will glow orange when the LEDs are ON to aid in setting this level. Also, while the control is being adjusted, the illuminator enters a “threshold setup” mode in which its light sensor response time is shortened so that the turn-on threshold can be quickly determined. While in this mode, the status LED will flash moderately quickly, either green if the LEDs are OFF, or orange if the LEDs are ON. After the threshold control has remained stationary for 30 seconds, the illuminator will return to normal operational mode, dramatically slowing down its response to ambient light levels to protect against false triggers, and to prevent ON/OFF oscillations.

12. Attach cord grip cover plate by sliding the loosened cord grips toward the illuminator, keeping the length of wire inside of the connector cavity as short as possible. Tighten the cover plate screws. Tighten the cord grips ¼ turn past snug to ensure a proper seal.



Failure to properly mount the illuminator to the installation surface may cause illuminator to fall. Make sure the ceiling is firm and stable enough to support the illuminator. If any reinforcement is needed, consult with your safety personnel and proceed with the installation.



When attaching your power supply to its connector please take extra care not to leave any exposed wire, as this may cause a short. If necessary, trim back the wires.



Infrared light produced by this illuminator is extremely bright, even though it is only weakly visible to the human eye. Limit exposure to the beam during installation and adjustment, when working in close proximity to the front of the product. Mount the illuminator well above eye height to limit exposure of others.

Step 2: Configuration

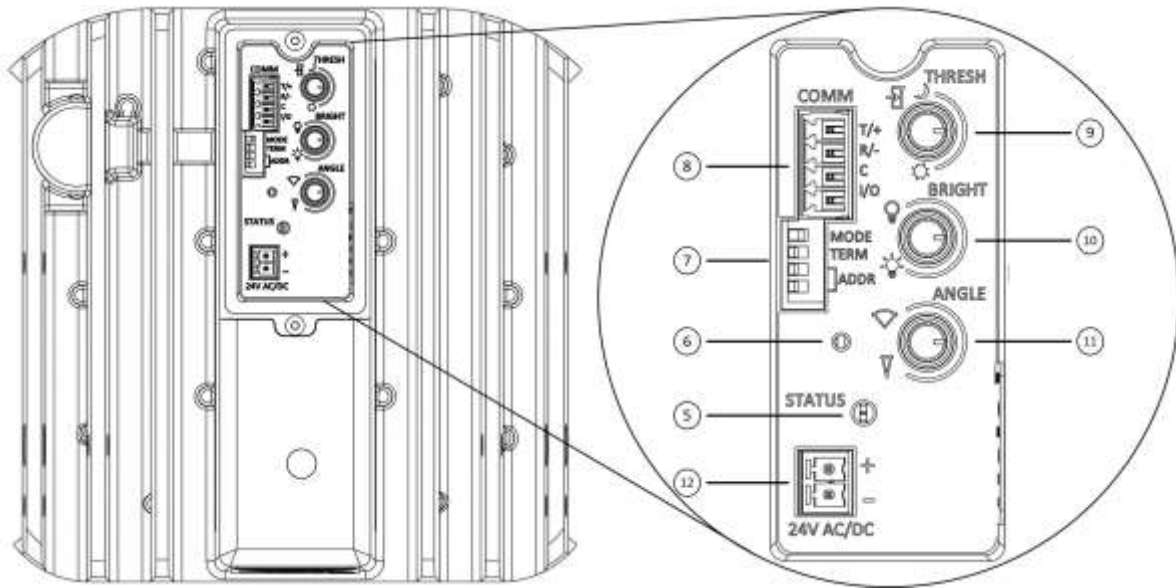

5 Status LED

The status LED indicates the system status with a green, red, or orange LED. While the unit is powering up, the green status LED will slowly flash until the unit is ready. Once it is, the green LED will be on solidly. If any of the controls are adjusted, the green status LED will flash rapidly. When the main LEDs turn ON, the green status LED is replaced by an orange one. It will remain on for as long as the main LEDs are ON. If the threshold control is adjusted (either using the control knob or via the serial communications interface), the green status LED will flash for 30 seconds after the control has been adjusted to indicate that the unit is in threshold setup mode. In the event of a fault, the red LED will stay on solidly until the fault is cleared and the unit is power cycled. During firmware upgrades, the orange LED will flash until the upgrade is complete, at which time it will turn off and the green LED will turn on solidly.

The table below shows the possible system conditions as indicated by the LED:

Condition	Color	State
Powering Up	Green	Slow Flash
Ready	Green	Solid
Controls Adjusted	Green	Fast Flash
Threshold Setup Mode	Green	Moderate Flashing
LEDs On	Orange	Solid
Firmware Upgrade	Orange	Fast Flashing
Fault	Red	Solid

6 Reset Button

Only use this button after contacting technical support.

7 RS232/RS485 DIP Switch

The DIP switch provides the following setting controls:

- **MODE:** RS-485 or RS-232 selection
 - When this switch is set to the left, the communication interface is configured to be half-duplexed (i.e., 2-wire) RS-485. The illuminator can be controlled by D Protocol at 2400 baud when in this mode.
 - When this switch is set as shown in the figure above (to the right), the communication

interface is configured to be full-duplexed RS-232. The illuminator can be controlled by NuOptic Control Protocol or D Protocol depending on the **ADDR** settings (see below).

- **TERM**: RS-485 bus termination enable
 - When this switch is set as shown in the figure above, no termination resistor is applied to the communication interface.
 - When this switch is set to the right, a 120 ohm termination resistor is connected between the D+ and D- signals. **IMPORTANT**: do not set this switch to the right if **MODE** switch is set to RS-232.
- **ADDR**: RS-485 bus address or RS-232 protocol selection
 - When **MODE** switch is set to RS-485, these two switches determine the bus address. The following table lists the possible bus addresses:

Switch Setting	Bus Address
Upper switch: LEFT Lower switch: LEFT	35
Upper switch: LEFT Lower switch: RIGHT	34
Upper switch: RIGHT Lower switch: LEFT	33
Upper switch: RIGHT Lower switch: RIGHT	32

- When **MODE** switch is set to RS-232, these two switches determine the protocol used. The following table lists the possible protocol combinations:

Switch Setting	Protocol	Baud Rate
Upper switch: LEFT Lower switch: LEFT	Firmware Upgrade	57600
Upper switch: LEFT Lower switch: RIGHT	NuOptic Control Protocol	57600
Upper switch: RIGHT Lower switch: LEFT	NuOptic Control Protocol	57600
Upper switch: RIGHT Lower switch: RIGHT	D Protocol	2400 (Bus Addr 32)

NOTE: Changes to the **MODE** and **ADDR** DIP switches do not take effect until after the unit is power cycled. Therefore, if you wish to make changes to **MODE** or **ADDR**, remove power from the unit, change the switches to their desired setting, then apply power to the unit. Changes to the **TERM** switch do not require power cycling – the effects are immediate.

8 Communication Interfaces

The illuminator supports RS232/485 serial communication and digital input/output. The serial communication utilizes 8 data bits, no parity, and 1 stop bit (8-N-1). Refer to Appendix D for more detailed digital input/output interface information.

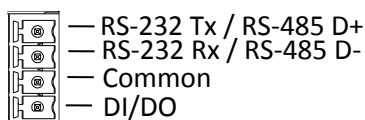

9 Ambient Light Threshold Adjustment Control

Use this control knob to set the ambient brightness level at which the illuminator will turn ON or OFF. Turning the control knob counter clockwise (CCW) makes the illuminator turn ON when the ambient light level is darker, and turning it clockwise (CW) makes the illuminator turn ON when the ambient light level is lighter.

In addition, this control knob affects the illuminator in the following ways:

- Turning the knob all the way CCW forces the illuminator to be OFF.
- Turning the knob all the way CW forces the illuminator to be ON.
- Any knob position between full CCW and full CW will cause the illuminator to turn ON and OFF based on the ambient light level and the knob setting as explained above.
- Additionally, when the knob is all the way CCW, DI/DO becomes DI input and controls whether the illuminator is ON or OFF. The illuminator turns ON by shorting DI to Common and turns OFF by open-circuiting DI. Any knob position except full CCW makes DI/DO become DO status output (High = OFF, Low = ON).

10 Brightness Adjustment Control

Use this control knob to set the brightness of the illuminator, counter clockwise for dimmer, clockwise for brighter.

11 Angle of Illumination Adjustment Control

Use this control knob to set the angle of the illuminator light, counter clockwise for wider, clockwise for narrower. The narrower the angle, the greater the illumination distance.

12 Power Connector

Connect the illuminator to a 24V AC or 24 – 36V DC power supply.